



ORIGINAL ARTICLE

Assessing the Psychometric Properties of Academic Engagement Questionnaire in Nursing Students

Jamil Sadeghifar¹, Hamidreza Baradaran Attar-moghaddam², Shahram Tofighi³, Marzie Tolide⁴, Mohamad Shariati^{5*}

¹ Department of Health Services Management, School of Health, Ilam University of Medical Sciences, Ilam, Iran

² Department of Epidemiology, School of Health, Iran University of Medical Sciences, Tehran, Iran

³ Iran Health Management Association, Tehran, Iran

⁴ Department E-learning in Medical Education, Tehran University of Medical Sciences, Tehran, Iran

⁵ Department of Community Medicine, School of Medicine, Tehran University of Medical Sciences, Tehran, Iran

ABSTRACT

Background: Academic Engagement is considered as one of the important factors related to the learners' academic achievement. It is known as a significant research issue in higher education. The present study aimed to make an instrument for investigating academic engagement among nursing students of Ilam University of Medical Sciences.

Methods: The present study is a methodological and cross-sectional research. To localize the academic engagement questionnaire, first, it was translated into Persian using forward-backward method. Then, its content and face validity were evaluated and approved. In order to determine the validity and reliability, the questionnaire was delivered to 120 nursing students and their comments were collected and analyzed. SPSS and AMOS software, statistical tests of exploratory factor analysis (EFA) and confirmatory factor analysis (CFA) were used for data analysis.

Results: According to the results, the internal consistency of the questionnaire was confirmed by calculating Cronbach's alpha coefficient ($\alpha = 0.906$). The EFA and CFA were used to examine the dimensionality of three domains of vigor, dedication, and absorption. Values of Goodness of Fit Index (GFI), Non-Normed Fit Index (NFI), Comparative Fit Index (CFI), and Root Mean Square Error of Approximation (RMSEA) indices were 0.89, 0.92, 0.90 and 0.97, respectively

Conclusion: The reliability and validity of the translated academic engagement questionnaire were relatively acceptable in reviewing the academic engagement of medical students, especially nursing students. Future studies should focus on more samples and examine the impact of nurses' background and educational variables on academic engagement.

Keywords: Academic Engagement, Student, Nursing, Psychometrics

Introduction

In academic contexts, engagement seems to be a necessary condition for preventing students' dropout and favoring high levels of academic success (1). Therefore, the study of academic engagement has flourished exponentially during the last decade, as shown by recent meta-analyses (2-5).

The academic engagement was a structure introduced to perceive and explain the academic failure. It was considered as a basis of reforming efforts in education (6). There are various proposed definitions and academic engagement models. In

Finn's model, academic engagement was compromised by two components including emotional and behavioral (behavioral, such as sustainability in lesson assignments, and emotional, such as valuing assignment and learning) (7).

Students' academic engagement in post-school education has been surveyed since the 1990s. It has always been regarded as a significant item in student learning and personal development during university courses (8). Researchers suggested different methods to explain students' academic

Corresponding Author: Mohamad Shariati

Email: shariati@tums.ac.ir

Tel: +98 2188962357

Tehran University of Medical Sciences, Tehran, Iran

Copyright: ©2024 The Author(s); Published by Shahid Sadoughi University of Medical Sciences. This is an open-access article distributed under the terms of the Creative Commons Attribution License (<https://creativecommons.org/licenses/by/4.0/>), which permits unrestricted use, distribution, and reproduction in any medium, provided the original work is properly cited.

engagement. It indicated the complexity of students' academic engagement concept. This concept has at least two general meanings. The first meaning refers to the degree of students' willingness to accept and comply with processes, values, and academic and organizational rules. Another one is focused on internal commitment and active engagement in achieving learning (9). The meaning of students' academic engagement in the present study is based on the second definition.

Educational institutions play a considerable role in students' academic engagement. 21st-century students were different significantly in terms of background, personality, and learning styles (10). Therefore, teachers should observe the motivation of students to engage them. So, the obtained results should be applied to improve the academic engagement of students with academic assignments (11).

The success or failure of a student's learning process includes factors that play an essential role such as self-esteem, motivation, and academic engagement (12). Engaged students were able to adapt themselves to the stressful conditions of the academic environment and were more satisfied as a result (13). In these situations, they may feel better and less stressed in the future when they become more professional; a syndrome to which health care professionals are traditionally faced (14).

Nursing students were taken into consideration in most of research studies in health science students (15), and focusing on the analysis of different teaching methods and using new teaching instruments. Key findings revealed that academic engagement was positively related to student participation, more active learning (16) and using new teaching technologies such as audience response systems (ARS), Clickers (17), and YouTube videos (18).

Examining the effective factors in academic engagement and non-engagement could lead to a proper understanding of student performance, retention, and promotion. The evaluation of the

student's academic engagement was potentially helpful when assessing the quality of student learning experiences and determining the resource preparation, course content, and lessons presentation methods (19). Generally, universities were directed towards measuring the learning outcomes of their students. Based on this, the National Survey of Student Engagement (NSSE) in the US and Canada since 2000 (20) and the Australian Survey of Student Engagement (AUSSE) since 2007 were used in higher education institutions in Australia and New Zealand (21). Educational engagement among Medical Sciences students in Iran has not already been considered dramatically. Hence, the present study was performed to localize the academic engagement instruments among nursing students of Ilam University of Medical Sciences.

Material and Methods

The present research was a cross-sectional, psychometric, and descriptive-analytical study. It was performed among all nursing students of nursing faculty of Ilam Medical Science University in February 2017.

At first, the required permission was obtained for the UWES-S (Utrecht work Engagement Scale for Student) questionnaire, which was designed by WB Schaufeli et al (22). A set of instructions, which were prepared by Ligia and Glorisa, was then used for translation and cultural adaptation of the instrument under the title of "toolkit on translation and cultural adaptation of an instrument" (23). In addition to Forward-translation, Back-translation process was applied in this study. In this method, the cultural and psychometric adaptation of the tool was stressed. The questionnaire was translated by a professional translator and then it was reviewed by a committee of three bilingual experts.

In the next step, the results of examining the translated questionnaire were evaluated in a bilingual committee through a focused group discussion (FGD) in a five-membered group. Based on the objective, these members were

selected among key informants and experts in the field. In addition to having appropriate knowledge on the subject of academic engagement, they also had sufficient experience related to the subject. Each item of the questionnaire was discussed, and questions 1, 3, 6, 11, and 14 were agreed without any change. Minor changes were applied to the rest of the questions.

After the completion of the FGD step, the Persian instrument was re-translated into English by a professional English translator (without access to the original English questionnaire). Then, the bilingual committee discussed the clarity of the phrases of the translated questionnaire, and the questionnaire was adapted, compared, and evaluated with the original questionnaire in order to determine any differences and prepare the Persian version.

The content and face validity were examined based on 20 experts' opinions. The questionnaire in a pilot study was distributed to 30 nursing students who were similar to the study population, and its reliability was initially evaluated. Face validity was measured through the Impact Score index. Then, the questionnaire was distributed among the studied population (120 nursing students). The method of calculating the sample size was as follows: The entire research population consisted of all undergraduate nursing students, regardless of their entry year. The inclusion criterion for the sample was that students were enrolled in the courses in the second semester of 2017-2018 academic year. Based on structural equation modeling using LISREL, approximately 9 students were selected for each of the 14 questionnaire items. Due to the small size of the research population, no sampling was conducted, and all nursing students at the university voluntarily participated in the study on a census basis.

The validity and reliability of the questionnaire were examined. EFA and CFA were applied to examine the validity of the questionnaire. Also, Cronbach's alpha coefficient was used to study the reliability of the questionnaire (internal consistency dimension).

The content and face validity were examined by opinions of 20 experts.

The applied questionnaire in the present study was adopted from Holgado's study (24) which was done among Spanish students. The questionnaire consisted of two parts. In the first part, information related to age, gender, and years of educations were requested. The second part composed of 14 questions in the three domains of vigor (5 questions), dedication (5 questions), and absorption (4 questions). Students answered each of the questions on the scales of always (4), most of the time (3), sometimes (2), rarely (1), and never (0).

Before distributing the questionnaires among the study samples, the required letter of introduction and permission was obtained. The paper version of the anonymous questionnaire was distributed by the researcher on the college campus among the students and was collected at that time. When the sample was not available, an electronic version of the questionnaire was sent to them. It should be mentioned that oral consent was also obtained from the students for completing the questionnaire.

Descriptive statistics like: frequency, percentage, mean, and standard deviation were applied to exhibit demographic variables and domains of academic engagement. In the inferential statistics, EFA and CFA tests were used. Moreover, SPSS software 20 and AMOS were observed to analyze the results.

Results

At first, the content validity ratio (CVR), content validity index (CVI), and face validity of questionnaire was determined. The experts' response regarding the calculation of the content validity ratio was coded in the forms of "necessary, useful but unnecessary and unnecessary". After calculating the CVR of each question and considering the number of experts which equals to 20, 0.42 was considered as an acceptable minimum for each question based on Lawshe's table. Therefore, questions with a CVR score below 0.42 were removed. So, one of the demographic questions, and two questions of the academic

engagement section were deleted. The mean CVR was equal to 0.61.

In CVI, simplicity, transparency, and relevance were examined. The CVI was calculated as 0.95. According to experts, questions with 0.70 CVI were acceptable. So, all questions were approved.

The Impact Score index was computed in order to determine the face validity of each item. Based on this index formula, the frequency in terms of percentage is the number of people who give 4 and 5 score to this item. The importance score refers to average importance score based on the mentioned Likert scale. If the impact score on face validity exceeded 1.5, the question would be considered appropriate. The face validity of all questions was optimum (the mean impact score was equal to 4.29).

After performing content and face validity, the mentioned questionnaire was given to 30 nursing students to evaluate the reliability and conducting pilot study. This group was similar to the study population. Then, the questionnaires were analyzed by calculating the Cronbach's alpha coefficient. The Cronbach's alpha coefficient of the whole questionnaire was equal to 0.93. According to the obtained reliability and validity and after applying the changes, finally a 16-item questionnaire (12 main questions and 4 questions related to demographic characteristics) was approved. Based on the statistical consultant, the limited number of questions and score close to acceptance, two of the three omitted questions were identified. This was done in order to eliminate only one demographic

question item which was related to determining the race and minority of students. Therefore, it was decided that the 18-item questionnaire, including 14 questions of academic engagement and 4 demographic questions, be given to the main samples of the study. In the next step, the questionnaire was presented to 120 nursing students, and the results were reported to assess the construct validity. Most of the study participants (59%) were female and unmarried (96.6%). About 2/3 of them were living in dormitories and 50% of the students were under 20 years old.

In addition to the content and face validity, construct validity, including EFA and CFA methods, was also applied to examine the validity of the questionnaire. Initially, EFA was performed using Principal Components Analysis (PCA) and varimax rotation for each scale. To obtain a good and correct number of factors, more than one factor of eigenvalues, Kaiser-Meyer-Olkin (KMO) factor and Barlett's test were used. In this study, the cut-point of 0.4 was considered as the minimum loading factor required to maintain each question in the factors extracted from the factor analysis. Exploratory analysis in the academic engagement questionnaire by KMO was equal to 0.867. Values more than 0.6 KMO statistics indicated the sampling adequacy. Bartlett's Test of Sphericity was equal to 809.756. P-value equal to 0.000 in Bartlett's test is significant at 0.05 level. The confidence level of zero for Bartlett's test also specified the adaptability of the factor model and the number of 14 questions loaded on three factors (Table 1).

Table 1. Rotated Component Matrix related to academic engagement

Components	Factors		
	1	2	3
My studies are very targeted and meaningful.	0.780		
While studying, it gives me a deep, pleasant feeling.	0.711		
When studying, I am attracted to the content.	0.690		
The material I study makes me think.	0.666		
My study makes me more inclined to me.	0.540		
I can continue my study for a long time.		0.785	
When studying, I feel powerful and decisive.		0.726	
While studying, I would mentally feel strong.		0.721	
When studying, I feel rich in energy and Vigor		0.671	
While studying, it gives me a deep, pleasant feeling.			0.819
When I wake up in the morning, I feel that I am eager to go to the classroom.			0.704
I am eager to learn about the scientific content of its courses.			0.620
When studying, I do not understand the time			0.575
When studying, nothing distracts me.			0.509

The obtained results from the EFA illustrated that three factors possessed an eigenvalue greater than 1, and only these factors were rotated. Furthermore, the three primary related factors had 63.133% variance. The structure of the proposed factor would encompass three

factors. Moreover, the output of the Scree Plot displayed that eigenvalue changes were minimized from the factor three onwards. Thus, these three factors could be extracted as the most noticeable ones explaining the variance of the data (Figure 1).

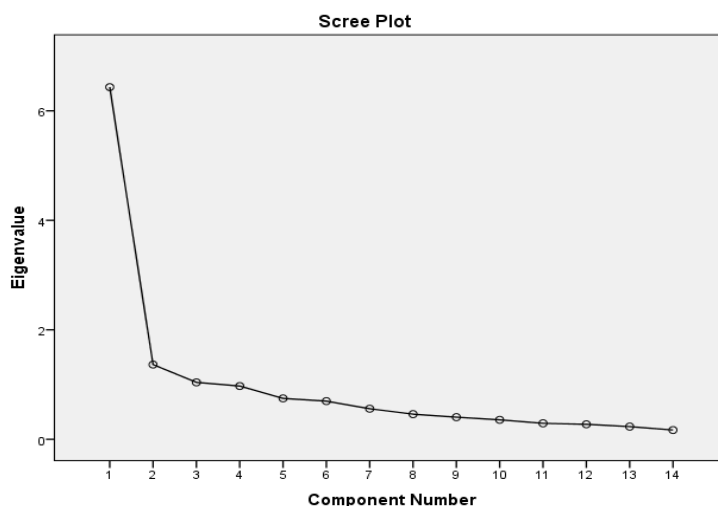

Figure 1. Scree Plot eigenvalues obtained from factors analysis

To determine the goodness of the proposed model with the intended data, CFA and fitness indices were used. The goodness of fit index (GFI), normal fitness index (NFI), comparative fit index (CFI), and root mean square error of

approximation (RMSEA) were equal to 0.89, 0.92, 0.90, and 0.977, respectively. Each of these values represented a good fit. It should be noted that the RMSEA index less than or equal to 0.05 showed good fit, between 0.05 and less than and

equal to 0.8 showed a reasonable and acceptable good fit, between 0.08 and less than and equal to 1 showed a medium fit and greater than 1 showed weak fit of the model. The ratio of Chi-squared to the corresponding degree of freedom less than 5 was acceptable and less than 3 was good. The results of the fit indices showed the

good fit of the model and confirmed the questions in the exploratory analysis. Questions 6, 7, 9, 12, and 14 were loaded on the first factor (dedication), questions 1, 2, 3, and 4 on the second factor (vigor), and questions 5, 8, 10, 11, and 13 were loaded on the third factor (absorption) (Figure 2).

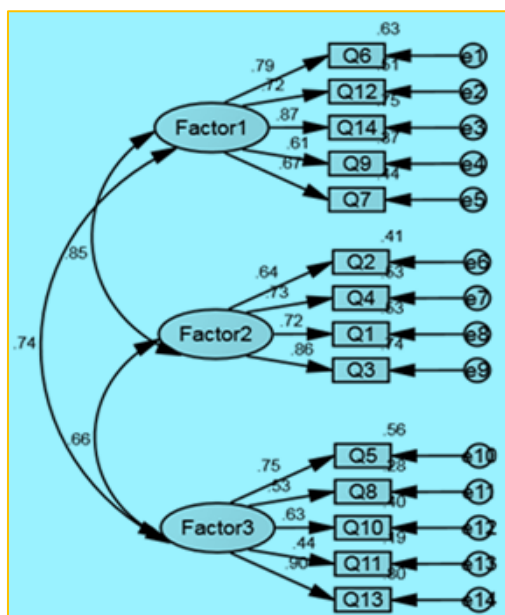

Figure 2. Factors loading plot

To determine the reliability of the questionnaire in the internal consistency method, the value of Cronbach’s alpha coefficient was obtained as 0.906 after completing the questionnaires. It shows that the questionnaire had a strong internal consistency (Table 2).

Table 2. Cronbach α of the questionnaire domains after the implementation of the study

Row	Dimensions	Number of Questions	Cronbach α
1	Dedication	5	0.847
2	Vigor	4	0.833
3	Absorption	5	0.773
Academic Engagement		14	0.906

Mean Impact Score = 4.29

Discussion

In the present study, the validity of the academic engagement instrument was investigated using

three content, face, and structural methods. The aim of the study was to indicate the way of evaluating the structure validity and assessing questionnaire validity in academic engagement. The results of EFA revealed that the factor loads of the majority of questions were higher than 0.5. In line with the current study, Salemla et al. (25) stated that the values of the reported goodness of fit indices were approximately better than the present study ones. The study by Scaphaly et al. (26) confirmed the present study findings. They indicated that academic engagement was defined by three interrelated factors including emotional fatigue towards school, pessimism about the concept of school, and inadequacy feeling at school. A three-factor model was obtained by Boles et al. (27). The reported that values of goodness fit indices in this model were weaker compared to the present study.

In the present study, CFA was applied to evaluate the validity of the questionnaire structure. The findings illustrated that the data were coordinated with the predetermined factor structure. It led to a structure with optimum reliability and validity. The fitness of the factor model also was along with findings of Wang et al. (28). Furthermore, other results of this study showed that academic engagement encompassed three dimensions of vigor, dedication and absorption. These findings were consistent with the research findings of Jimerson et al. (29), Klem and Connell (30), and Yazzie-Mintz (31). (28)

Cronbach's alpha coefficient was used to estimate the internal consistency of academic engagement, after factor analysis. The value of Cronbach's alpha coefficient was equal to 0.906. It indicated that the questionnaire has strong internal consistency. Nunally and Bernstein (32) proposed an internal consistency coefficient greater than 0.7. Comparing the obtained coefficients in this study with studies by Wigfield et al. (26) and Salmela et al. (25), it was revealed that the estimated reliability for the overall scale and subscales were appropriate.

Conclusion

Compared to studies in this field and due to non-adaptability of other mentioned instruments, this questionnaire is recommended to be used as a practical instrument to assess academic engagement and its components. Moreover, in terms of the reliability and validity, the present questionnaire was almost similar and satisfactory relative to the original version and the existed tools in this field. The obtained results from the implementation of the mentioned questionnaire could be applied to promote academic engagement and its components in the classroom. Furthermore, the data from this questionnaire was a useful and available tool for teachers to assess and monitor the level and aspects of students' academic engagement.

Based on the findings, the educational engagement questionnaire is reliable. It can also be used to

measure academic engagement among nursing students. It is suggested to researchers to focus on more samples in future studies, and they can investigate the impact of background and educational variables of nurses on their academic engagement.

Limitations

The sample size was selected using the census method and includes only one group of medical students (120 person), but the number of participants was limited.

Ethical Consideration

This research was approved by the Ethics Committee of Tehran University of Medical Sciences (grant No: TUMS-18- 424-1060).

Acknowledgement

We would like to extend our gratitude to the participants in the Nursing students of Ilam University of Medical Sciences.

Conflict of Interest

The authors declared no conflict of interest.

Author's Contribution

Study concept and design: M.Sh, J.S and H.B. Statistical analysis and interpretation of data: J.S and H.B. Drafting the manuscript: J.S and M.T. Critical revision of the manuscript: J.S, M.Sh and Sh.T.

Funding

This study was a part of the MSc thesis of the first author at the Department e-Learning in Medical Education, Virtual University of Medical Sciences, Tehran University of Medical Science. It was financially supported by the Research Committee of Tehran University of Medical Science.

References

1. Lei H, Cui Y, Zhou W. Relationships between student engagement and academic achievement: A meta-analysis. *Social Behavior and Personality: an international journal*. 2018;46(3):517-28.

2. Boulianne S, Theocharis Y. Young people, digital media, and engagement: A meta-analysis of research. *Social science computer review*. 2020;38(2):111-27.
3. Jansen RS, Van Leeuwen A, Janssen J, Jak S, Kester L. Self-regulated learning partially mediates the effect of self-regulated learning interventions on achievement in higher education: A meta-analysis. *Educational Research Review*. 2019;28:100292.
4. Myint KM, Khaing NN. Factors influencing academic engagement of university students: A meta-analysis study. *Journal of Myanmar Academic Arts and Sciences*. 2020;18(9b):185-99.
5. Young HR, Glerum DR, Wang W, Joseph DL. Who are the most engaged at work? A meta-analysis of personality and employee engagement. *Journal of Organizational Behavior*. 2018;39(10):1330-46.
6. Fredricks JA, Blumenfeld PC, Paris AH. School engagement: Potential of the concept, state of the evidence. *Review of educational research*. 2004;74(1): 59-109.
7. Finn JD. Withdrawing from school. *Review of educational research*. 1989;59(2):117-42.
8. Pascarella ET. How college affects students: Ten directions for future research. *Journal of college student development*. 2006;47(5):508-20.
9. Chapman E. Alternative approaches to assessing student engagement rates. *Practical Assessment, Research, and Evaluation*. 2019;8(1):13.
10. DiLullo C, McGee P, Kriebel RM. Demystifying the Millennial student: A reassessment in measures of character and engagement in professional education. *Anatomical sciences education*. 2011;4(4):214-26.
11. Zepke N, Leach L, Butler P. Engagement in post-compulsory education: students' motivation and action. *Research in Post-Compulsory Education*. 2010;15(1):1-17.
12. Mayer JD. An integrated approach to personality assessment based on the personality systems framework. *Journal of Personality Assessment*. 2020;102(4):443-56.
13. Lewis AD, Huebner ES, Malone PS, Valois RF. Life satisfaction and student engagement in adolescents. *Journal of youth and adolescence*. 2011;40:249-62.
14. Ahola K, Hakonen J. Burnout among health care professionals. *Duodecim; Laaketieteellinen Aikakauskirja*. 2010;126(18):2139-46.
15. Ghasemi MR, Moonaghi HK, Heydari A. Student-related factors affecting academic engagement: A qualitative study exploring the experiences of Iranian undergraduate nursing students. *Electronic physician*. 2018;10(7):7078.
16. LM S. *Engaging Students' Learning in the Built Environment Through Active Learning. Claiming Identity Through Redefined Teaching in Construction Programs*: IGI Global; 2020.
17. Mauldin Pereira M, Artemiou E, Conan A, Köster L, Cruz-Martinez L. Case-based studies and clinical reasoning development: Teaching opportunities and pitfalls for first year veterinary students. *Medical Science Educator*. 2018;28:175-9.
18. Johnston AN, Barton MJ, Williams-Pritchard GA, Todorovic M. Youtube for millennial nursing students; using internet technology to support student engagement with bioscience. *Nurse education in practice*. 2018;31:151-5.
19. Coates H. A model of online and general campus-based student engagement. *Assessment & Evaluation in Higher Education*. 2007;32(2):121-41.
20. Lutz ME, Culver S. The national survey of student engagement: A university-level analysis. *Tertiary Education and Management*. 2010;16(1):35-44.
21. Coates H. Development of the Australasian survey of student engagement (AUSSE). *Higher Education*. 2010;60(1):1-17.
22. Schaufeli WB, Martinez IM, Pinto AM, Salanova M, Bakker AB. Burnout and engagement in university students: A cross-national study. *Journal of cross-cultural psychology*. 2002;33(5):464-81.
23. Chávez LM, Canino G. *Toolkit on translating and adapting instruments*. Cambridge, MA: Human Services Research Institute. 2005:9-14.
24. Casuso-Holgado MJ, Cuesta-Vargas AI, Moreno-Morales N, Labajos-Manzanares MT, Barón-López FJ, Vega-Cuesta M. The association between academic engagement and achievement in health sciences students. *BMC medical education*. 2013;13:1-7.
25. Salmela-Aro K, Kiuru N, Leskinen E, Nurmi J-E. School burnout inventory (SBI) reliability and validity. *European journal of psychological assessment*. 2009;25(1):48-57.
26. Wigfield A EJ, Schiefele U, Roeser R, Davis-Kean P. . Development of achievement motivation (In W. Damon & N. Eisenberg (Eds.). *Handbook of child psychology* (Vol. 3, pp. 933-1002). : New York: Wiley; ;

- 2006.
27. Boles JS, Dean DH, Ricks JM, Short JC, Wang G. The dimensionality of the Maslach Burnout Inventory across small business owners and educators. *Journal of Vocational Behavior*. 2000;56(1):12-34.
28. Wang M-T, Willett JB, Eccles JS. The assessment of school engagement: Examining dimensionality and measurement invariance by gender and race/ethnicity. *Journal of school psychology*. 2011; 49(4):465-80.
29. Jimerson SR, Campos E, Greif JL. Toward an understanding of definitions and measures of school engagement and related terms. *The California School Psychologist*. 2003;8:7-27.
30. Klem AM, Connell JP. Relationships matter: Linking teacher support to student engagement and achievement. *Journal of school health*. 2004;74:262-73.
31. Yazzie-Mintz E. Voices of students on engagement: A report on the 2006 high school survey of student engagement. Center for Evaluation and Education Policy, Indiana University. 2007.
32. Nunnally JC. Psychometric theory—25 years ago and now. *Educational Researcher*. 1975;4(10):7-21.